

GLOBAL JOURNAL OF ENGINEERING SCIENCE AND RESEARCHES
HYDROMAGNETIC SQUEEZE FILM LUBRICATION BETWEEN ROUGH
PARALLEL STEPPED PLATES

Hanumagowda B. N.^{*1}, J. Santhosh Kumar² & Nagarajappa C. S.³

^{*1,2&3}School of Applied Sciences, REVA University, Bangalore – 560064, INDIA

ABSTRACT

A theoretical study of the effects of Magneto-hydrodynamic (MHD) and surface roughness on squeeze film parallel stepped plates. The modified Reynolds equation is derived on the basis of Magneto-hydrodynamic (MHD) thin film lubrication theory and Christensen stochastic theory. The Reynolds equation is solved for pressure, load carrying capacity and squeezing time. It is observed that the effect of transverse (longitudinal) roughness pattern is to increase (decrease) the pressure, load carrying capacity and squeeze film time compared with smooth surface case.

Keywords: *Magneto-hydrodynamics (MHD), surface roughness, and parallel stepped plates.*

I. INTRODUCTION

In engineering application, the magneto-hydrodynamics (MHD) bearings have advantages in improving the performance of the bearings when the bearing is lubricated with electrically conducted fluid in the presence of external magnetic field. Motivated by this, experimental and theoretical research has been carried out on different MHD bearings [1-10]. All these studies are based on the assumption that the bearing surfaces are perfectly smooth. However, all the bearings are rough in nature to some extent and they are not ideally smooth in realistic. Christensen [11] developed a stochastic model for hydrodynamic lubrication of rough surface. On the basis of this model, several researchers have studied the effects of surface roughness on the performance of the various bearings. For example, Christensen and Tonder[12] analyzed journal bearing, Gupta and Deheri [13] discussed the squeeze film behavior of spherical bearing, Turaga et al.[14] analyzed the hydrodynamic journal bearing with rough surfaces, hydrodynamic lubrication of slider bearing by Andheria et al. [15], the oscillating squeeze-film behavior of long partial journal bearings by Line et al.[16], the squeeze film behavior of curved circular plates Naduvinamani and Gurubasavaraj [17], the squeeze film lubrication of curved annular plates by Bujurke and Naduvinamani[18].The effect of two different roughness on the squeeze-film characteristics for MHD parallel stepped plates has not been studied so far .Hence, the present investigation aims to study the effects of two roughness patterns on the squeeze film characteristics of parallel stepped plates.

II. MATHEMATICAL FORMULATION OF THE PROBLEM:

The configuration of MHD parallel stepped plates with roughness patterns and having length L is shown in Fig.1. It is assumed that the lower plate with roughness patterns is fixed and an upper plate approaching the lower plate with a normal velocity $V \left(= -\frac{dh}{dt} \right)$. The uniform transverse magnetic field is applied perpendicular to the plates. Under

the usually assumptions of MHD flow problems, the governing equations of present problem are considered as:

$$\frac{\partial^2 u}{\partial z^2} - \frac{M_0^2}{h_0^2} u = \frac{1}{\mu} \frac{\partial p}{\partial x} \quad (1)$$

$$\frac{\partial p}{\partial z} = 0 \quad (2)$$

$$\frac{\partial u}{\partial x} + \frac{\partial w}{\partial z} = 0 \quad (3)$$

Where u, v represent the velocity components along x and z direction respectively, p is the pressure, h_2 is the minimum film thickness, μ is the dynamic viscosity and η represents a new material constant and $M_0 = B_0 h_2 (\sigma/\mu)^{1/2}$ is the Hartmann number.

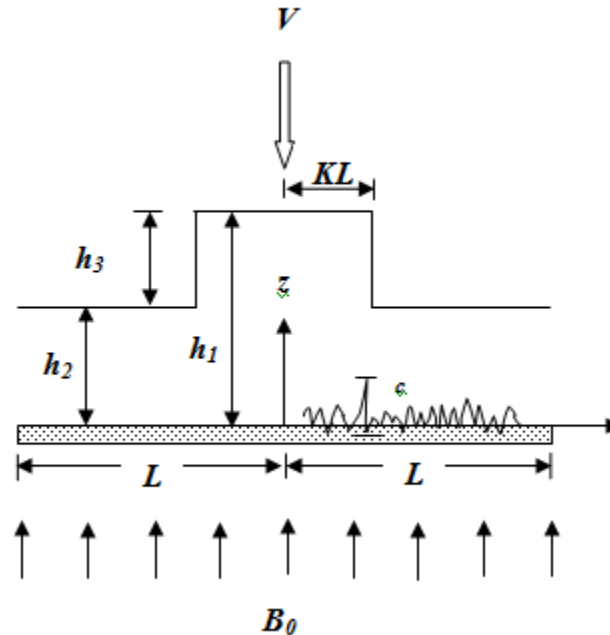

Figure 1 MHD Rough Parallel stepped plates

The appropriate boundary conditions for velocity components are as follows:

- (i) At the upper surface $z = h$
 $u = 0, w = -V$ (4)
- (ii) At the lower surface $z = 0$

$$u = 0, w = 0 \tag{5}$$

The expression for velocity component can be found by solving (1) subject of the conditions (4) and (5), we get

$$u = \frac{h_2^2}{\mu M_0^2} \frac{\partial p}{\partial x} \left\{ \text{Cosh}(M_0 z/h_2) - 1 - \frac{\text{Cosh}(M_0 h/h_2) - 1}{\text{Sinh}(M_0 h/h_2)} \text{Sinh}(M_0 z/h_2) \right\} \tag{6}$$

The Volume flux of the lubricant for the breadth of the bearing b can be expressed as

$$Q = b \int_0^h u dz \tag{7}$$

We should note that $Q = 0$ at $x = 0$.

Using the expression for u and further evaluating the integral, one can obtain the expression for volume flux Q as:

$$Q = -\frac{bh_0^3}{\mu} \frac{\partial p}{\partial x} f(h, M_0) \quad (8)$$

Where

$$f(h, M_0) = \frac{1}{M_0^3} \left(\frac{M_0 h}{h_0} - 2 \tanh \frac{M_0 h}{2h_0} \right)$$

Integrating the continuity equation (3) across the cross thickness using equation (6), one can derive the MHD Reynolds equation as:

$$\frac{\partial}{\partial x} \left\{ \frac{\partial p}{\partial x} f(h, M_0) \right\} = \frac{\mu V}{h_2^3} \quad (9)$$

Reynolds equation in region I and region II is

$$\frac{\partial}{\partial x} \left\{ \frac{\partial p_i}{\partial x} f_i(h_i, M_0) \right\} = \frac{\mu V}{h_2^3} \quad (10)$$

$$f_i(h_i, M_0) = \frac{1}{M_0^3} \left(\frac{M_0 h_i}{h_2} - 2 \tanh \frac{M_0 h_i}{2h_2} \right)$$

where $p_i = p_1$ and $h_i = h_1$ in the region $0 \leq x \leq KL$

$p_i = p_2$ and $h_i = h_2$ in the region $KL \leq x \leq L$

To mathematically model the surface roughness, the fluid film thickness is considered to be made up of two parts

$$H_i = h_i + h_s(x, z, \xi) \quad (11)$$

Let $f(h_s)$ be the probability density function of the stochastic film thickness h_s . Taking the stochastic average of modified Reynolds equation (10) with respect to $f(h_s)$, the stochastic MHD Reynolds equation is obtained in the form

$$\frac{\partial}{\partial x} \left\{ \frac{\partial E(p_i)}{\partial x} E(f_i(H_i, M_0)) \right\} = \frac{\mu V}{h_2^3} \quad (12)$$

$$\text{where } E(*) = \int_{-\infty}^{\infty} (*) f(h_s) dh_s$$

For most of the lubricating surfaces, the Gaussian distribution for describing the roughness profile heights is valid up to at least three standard deviations. Following Christensen, the roughness distribution function is assumed in the form

$$f(h_s) = \begin{cases} \frac{35}{32c^7} (c^2 - h_s^2)^3 & -c < h_s < c \\ 0 & \text{elsewhere} \end{cases}$$

where $c = 3\sigma$ and σ is the standard deviation.

In the context of Christensen's stochastic theory for the hydrodynamic lubrication of rough surfaces, two types of one dimensional roughness patterns are considered viz., the longitudinal roughness patterns and the transverse roughness patterns.

2.1 Longitudinal Roughness Pattern

The longitudinal one-dimensional roughness, having the run in x -direction in the form of long narrow ridges and a valley. In this case the film thickness assumes in the form $H_i = h_1 + h_s(z, \xi)$, and the average modified Reynolds equation (12) takes the form

$$\frac{\partial}{\partial x} \left\{ \frac{\partial E(p_i)}{\partial x} E(f_i(H_i, M_0)) \right\} = \frac{\mu V}{h_2^3}. \quad (13)$$

2.2 Transverse Roughness Pattern

The transverse one-dimensional roughness, having the run in z -direction in the form of long narrow ridges and narrow. In this case the film thickness assumes in the form $H_i = h_1 + h_s(x, \xi)$, and the averaged MHD Reynolds equation (12) takes the form

$$\frac{\partial}{\partial x} \left\{ \frac{\partial E(p_i)}{\partial x} \frac{1}{E f_i(H_i, M_0)} \right\} = \frac{\mu V}{h_2^3} \quad (14)$$

Equations (13) and (14) together can be expressed as

$$\frac{\partial}{\partial x} \left\{ \frac{\partial E(p_i)}{\partial x} G(H_i, M_0, c) \right\} = \frac{\mu V}{h_2^3} \quad (15)$$

where $H_i = h_1 + h_s$ and $E(p_i) = E(p_1)$ for the region $0 \leq x \leq KL$

$H_i = h_2 + h_s$ and $E(p_i) = E(p_2)$ for the region $KL \leq x \leq L$

$$G(H_i, M_0, c) = \begin{cases} E(f_i(H_i, M_0)) & \text{for longitudinal roughness} \\ \{E(1/(f_i(H_i, M_0)))\}^{-1} & \text{for transverse roughness} \end{cases}$$

$$E(f_i(H_i, M_0)) = \frac{35}{32c^7} \int_{-c}^c f_i(H_i, M_0)(c^2 - h_s^2)^3 dh_s$$

$$E\left(\frac{1}{f_i(H_i, M_0)}\right) = \frac{35}{32c^7} \int_{-c}^c \frac{(c^2 - h_s^2)^3}{f_i(H_i, M_0)} dh_s$$

The appropriate boundary conditions for mean pressure are as follows

$$E(p_1) = 0 \text{ at } x = 0 \text{ and } x = L \quad (16a)$$

$$E(p_1) = E(p_2) \text{ at } x = KL, \quad (16b)$$

Integrating equation (15) and using the boundary conditions (16a) and (16b), we get

$$E(p_1) = \frac{\mu V}{2h_2^3} \left\{ \frac{K^2 L^2 - x^2}{G(H_1, M_0, c)} + \frac{L^2(1-K^2)}{G(H_2, M_0, c)} \right\} \quad (17)$$

$$E(p_2) = \frac{\mu V}{2h_2^3} \frac{(L^2 - x^2)}{G(H_2, M_0, c)} \quad (18)$$

Introducing non-dimensional quantities

$$H_1^* = h_1^* + h_s^*, H_2^* = 1 + h_s^*, h_1^* = \frac{h_1}{h_2}, h_s^* = \frac{h_s}{h_2}, C = \frac{c}{h_2}, P_i = \frac{2E(p_i)h_2^3}{\mu VL^2}$$

The non-dimensional mean pressure distribution of the squeeze film in the region $0 \leq x \leq KL$ and $KL \leq x \leq L$ are expressed as:

$$P_1 = \frac{2E(p_1)h_2^3}{\mu VL^2} = \left\{ \frac{K^2 - x^{*2}}{G_1^*(H_1^*, M_0, C)} + \frac{(1 - K^2)}{G_2^*(H_2^*, M_0, C)} \right\} \quad (19)$$

$$P_2 = \frac{2E(p_2)h_2^3}{\mu VL^2} = \frac{(1 - x^{*2})}{G_2^*(H_2^*, M_0, C)} \quad (20)$$

$$G_i^*(H_i^*, M_0, C) = \begin{cases} E(f_i^*(H_i^*, M_0)) & \text{for longitudinal roughness} \\ \{E(1/f_i^*(H_i^*, M_0))\}^{-1} & \text{for transverse roughness} \end{cases}$$

$$E(f_i^*(H_i^*, M_0)) = \frac{35}{32C^7} \int_{-C}^C f_i^*(H_i^*, M_0)(C^2 - h_s^{*2})^3 dh_s^*$$

$$E\left(\frac{1}{f_i^*(H_i^*, M_0)}\right) = \frac{35}{32C^7} \int_{-C}^C \frac{(C^2 - h_s^{*2})^3}{f_i^*(H_i^*, M_0)} dh_s^*$$

$$f_1^*(H_1^*, M_0) = \frac{1}{M_0^3} \left(M_0 H_1^* - 2 \tanh \frac{M_0 H_1^*}{2} \right)$$

$$f_2^*(H_2^*, M_0) = \frac{1}{M_0^3} \left(M_0 H_2^* - 2 \tanh \frac{M_0 H_2^*}{2} \right)$$

The load carrying capacity $E(W)$ is determined by

$$E(W) = 2b \int_0^{KL} p_1 dx + 2b \int_{KL}^L p_2 dx = \frac{2\mu b L^3 V}{3h_2^3} \left\{ \frac{K^3}{G(H_1, M_0, c)} + \frac{(1 - K^3)}{G(H_2, M_0, c)} \right\} \quad (21)$$

The load carrying capacity in non-dimensional form can be expressed as:

$$W^* = \frac{3E(W)h_2^3}{2b\mu L^3 V} = \frac{K^3}{G_1^*(H_1^*, M_0, C)} + \frac{(1 - K^3)}{G_2^*(H_2^*, M_0, C)} \quad (22)$$

Writing in equation (21), the time of approach is given by Writing $V = -\frac{dh_2}{dT}$ in equation (30), the time of approach for reducing the film thickness from an initial value h_0 of h_2 to a final value h_f is given by

$$T = -\frac{2b\mu L^3}{3Wh_0^3} \int_{h_0}^{h_f} \left\{ \frac{K^3}{G(H_1, M_0, c)} + \frac{(1 - K^3)}{G(H_2, M_0, c)} \right\} dh_2 \quad (23)$$

Taking non-dimensional quantities

$$h_f^* = \frac{h_f}{h_0}, h_3^* = \frac{h_3}{h_0}, h_s^* = \frac{h_s}{h_0}, M_0 = B_0 h_0 \left(\frac{\sigma}{\mu}\right)^{1/2}$$

$$T^* = -\frac{3Wh_0^2 T}{2b\mu L^3} = \int_1^{h_1^*} \left\{ \frac{K^3}{G_1^*(h_2^*, h_3^*, h_s^*, M_0, C)} + \frac{(1-K^3)}{G_2^*(h_2^*, h_s^*, M_0, C)} \right\} dh_2^* \quad (24)$$

where $G_1^*(h_2^*, h_3^*, h_s^*, M_0, C) = \begin{cases} E(f_1^*(h_2^*, h_3^*, h_s^*, M_0, C)) & \text{for longitudinal roughness} \\ \{E(1/(f_1^*(h_2^*, h_3^*, h_s^*, M_0, C)))\}^{-1} & \text{for transverse roughness} \end{cases}$

$G_2^*(h_2^*, h_s^*, M_0, C) = \begin{cases} E(f_2^*(h_2^*, h_s^*, M_0, C)) & \text{for longitudinal roughness} \\ \{E(1/(f_2^*(h_2^*, h_s^*, M_0, C)))\}^{-1} & \text{for transverse roughness} \end{cases}$

$f_1^*(h_2^*, h_3^*, h_s^*, M_0) = \frac{1}{M_0^3} \left\{ M_0(h_2^* + h_3^* + h_s^*) - 2 \tanh \frac{M_0(h_2^* + h_3^* + h_s^*)}{2} \right\}$

III. RESULTS AND DISCUSSION

The influence of surface roughness on the squeeze film behavior of MHD parallel stepped plates with an electrically conducted fluid in the presence of transverse magnetic field is investigated. The roughness parameter C which characterises the surface roughness on the basis of the Christensen stochastic theory [11] and the Hartmann number M_0 signifies the effect of magnetic field. Taking $M_0 = 0(2)4$, $K=0.6(0.1)0.8$ and $C=0(0.4)0.8$, the characteristic of bearing are presented.

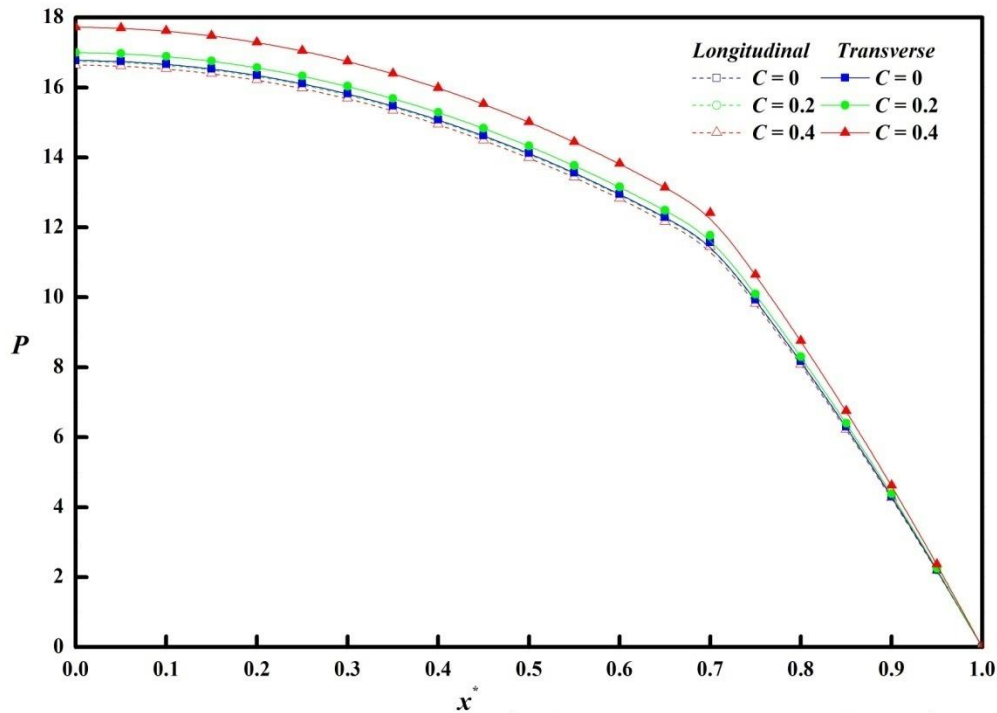

Figure 2 Variation of non-dimensional pressure P with x^* for different values of C with $M_0 = 3, K = 0.7, h_1^* = 1.5$

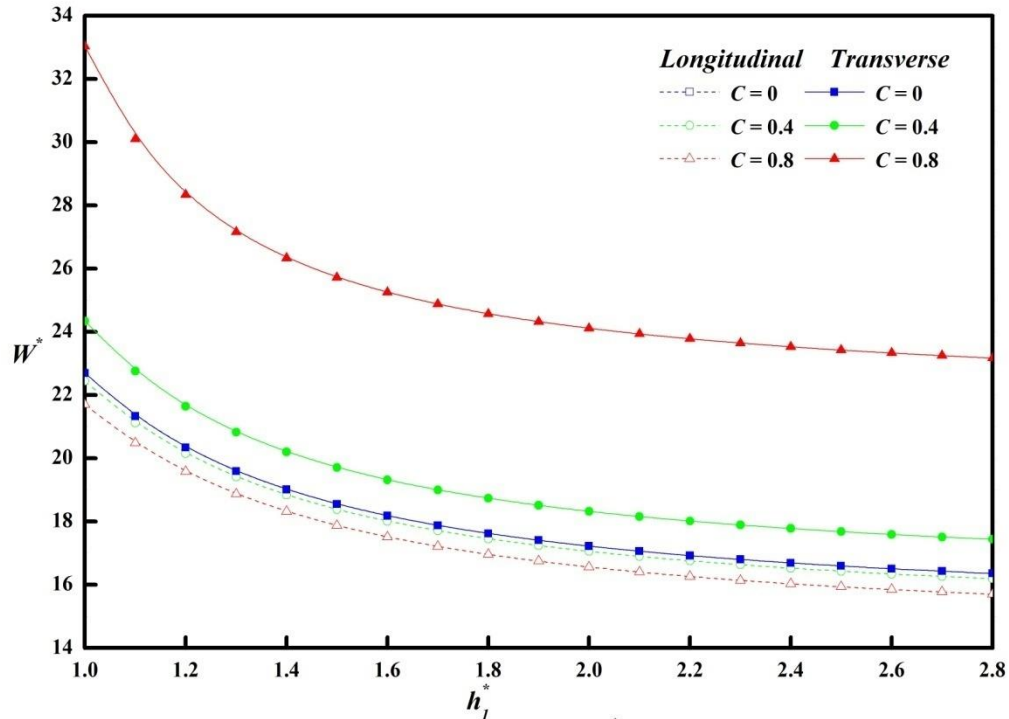

Figure 3 Variation of non-dimensional Load carrying capacity W with h_1^* for different values of C with $M_0 = 3, K = 0.7$

Pressure

Fig.2 illustrates the variation of mean pressure distribution P with coordinate x^* for both roughness patterns, for fixed parameters $M_0 = 3, K = 0.7, h_1^* = 1.5$. It is found from the figure that, longitudinal(transverse) roughness results a decrease(increase) in P as compared with a conventional bearing. Since the patterns of longitudinal roughness has ridges and valleys in longitudinal direction results in an increase in the circumferential flow, the bearing pressure is reduced. On the other hand, the patterns of transverse roughness has ridges running in the transverse direction, it leads to restrict available flow area and thus reduce the fluid flow. This leads to an increase in squeeze film pressure. Hence, the influence of longitudinal roughness is reverse.

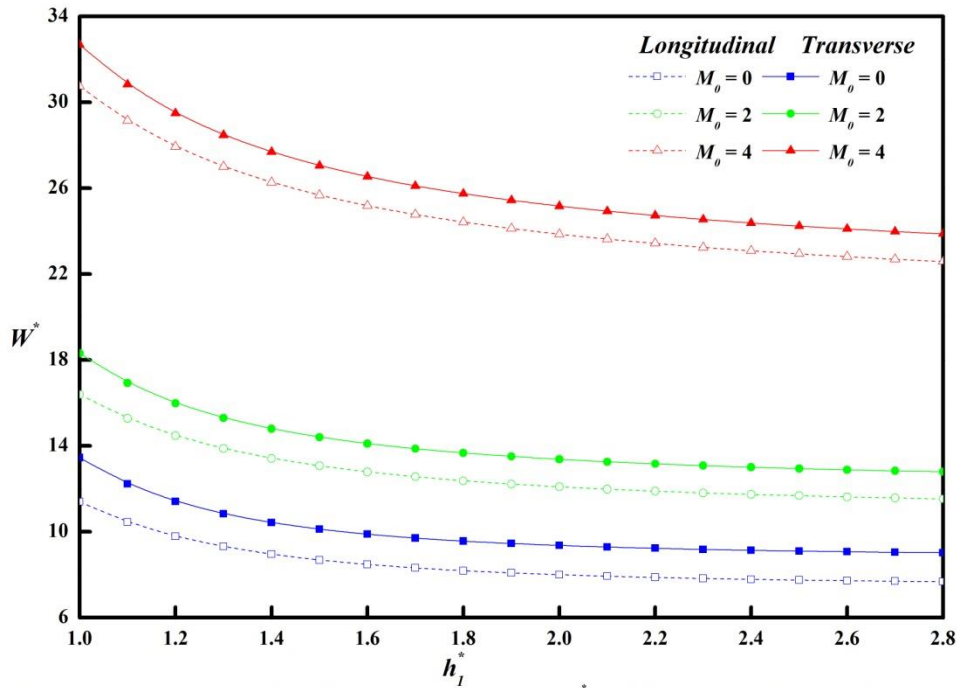

Figure 4 Variation of non-dimensional Load carrying capacity W with h_1^* for different values of M_0 with $C=0.4, K=0.7$

Load carrying capacity

The load- carrying capacity W^* verses h_1^* for both roughness patterns is illustrated in Fig.3 for fixed parameters $M_0 = 3, K = 0.7$. It is observed that the effect of roughness is to increase W^* for decreasing the values of h_1^* . Also load carrying capacity decrease (increase) for longitudinal (transverse) roughness patterns. The non-dimensional load- carrying capacity W^* as a function of h_1^* for different values of Hartmann number M_0 is illustrated in Fig.4 for fixed parameters $C=0.4$ and $K=0.7$. It is interesting to note that W^* increases for increasing the values of Hartmann number M_0 . Fig.5 illustrates the load W^* as a function non-dimensional film height h_1^* for different values of κ . It is observed that W^* decreases for increasing values of κ . Fig.6 illustrates the load W^* as a function rise location parameter κ for both roughness patterns. It is observed that W^* decreases for increasing the values of κ .

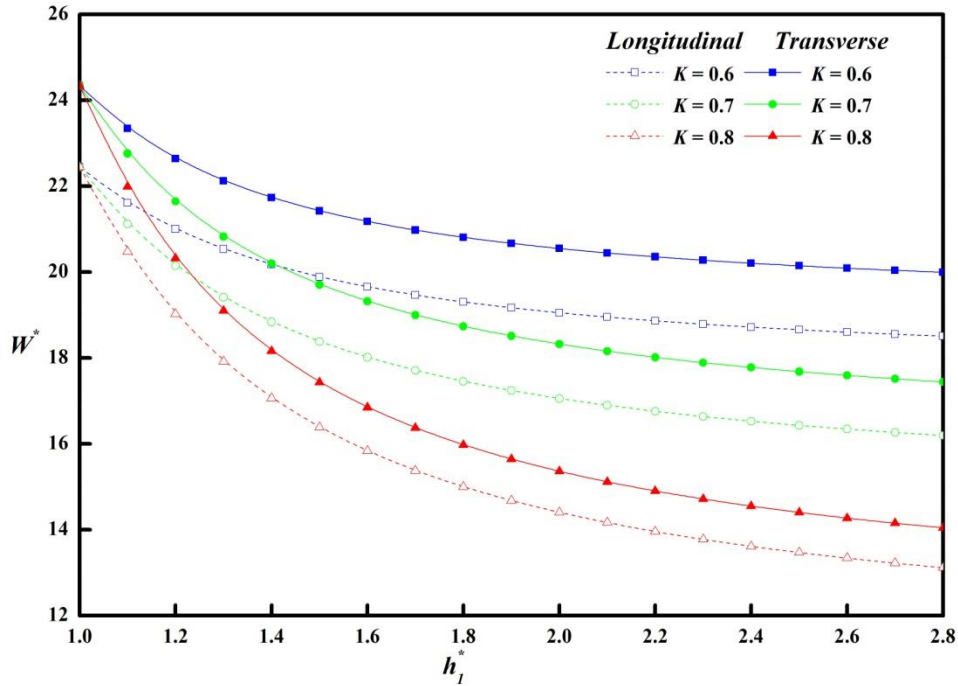

Figure 5 Variation of non-dimensional Load carrying capacity W^* with h_1^* for different values of K with $C = 0.4, M_0 = 3$

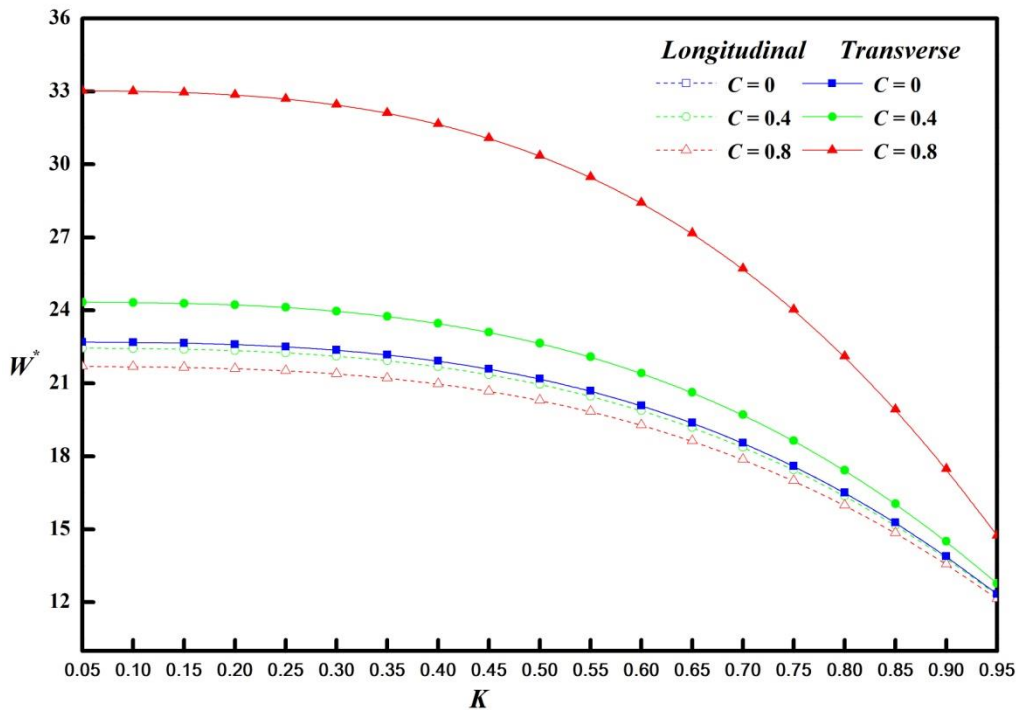

Figure 6 Variation of non-dimensional Load carrying capacity W^* with K for different values of C with $M_0 = 3, h_1^* = 1.5$.

Squeezing time

The film thickness and time relation is the one of the important characteristics of the squeeze film bearings. It is found that the time required for reducing the initial film thickness h_2 of h_0 to a prescribed final value h_f . Fig.7 illustrates the squeezing time T^* as a function h_f for various values of roughness parameter C for both longitudinal and transverse roughness patterns. It is interested to note that T^* decreases with increasing values of h_f . Further it is noticed that T^* increases (decreases) for increasing values of transverse (longitudinal) roughness pattern. The squeezing time T^* verses h_f^* for different values of K is illustrated in Fig.8. It is clearly observed that T^* decreases for increasing values of K . Fig.9 shows the variation of T^* with h_f^* for distinct values of M_0 . It is observed that T^* increases with increasing values of M_0 . The squeezing time T^* verses K is illustrated in Fig.10 for both roughness patterns. It is found that T^* decreases for increasing values of K .

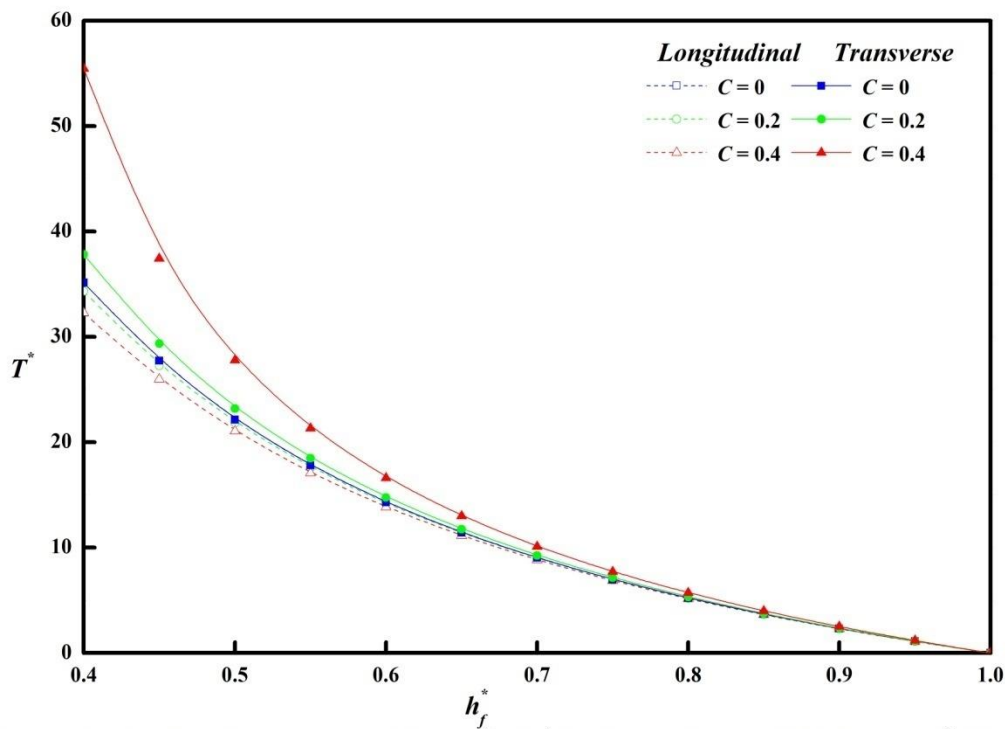

Figure 7 Variation of non-dimensional squeeze film time T^* with h_f^* for different values of C with $M_0 = 3$, $K = 0.7$, $h_3^* = 0.15$

IV. CONCLUSIONS

The effect of surface roughness and MHD on parallel stepped plates is studied on the basis of Christensen stochastic model. Two types of roughness patterns (viz., longitudinal and transverse) were considered. The exact expressions for pressure, load carrying capacity and squeezing time are obtained analytically. The results are presented graphically. The important conclusions can be summarized as follows:

1. The presence of magnetic field improves the pressure distribution, load and increases the squeezing time for both longitudinal and transverse roughness patterns.
2. The transverse roughness patterns increase the pressure, load and squeezing time.
3. The longitudinal roughness patterns decrease the pressure, load and the response time.
4. The pressure, load carrying capacity and squeezing time decrease with increasing value of K .

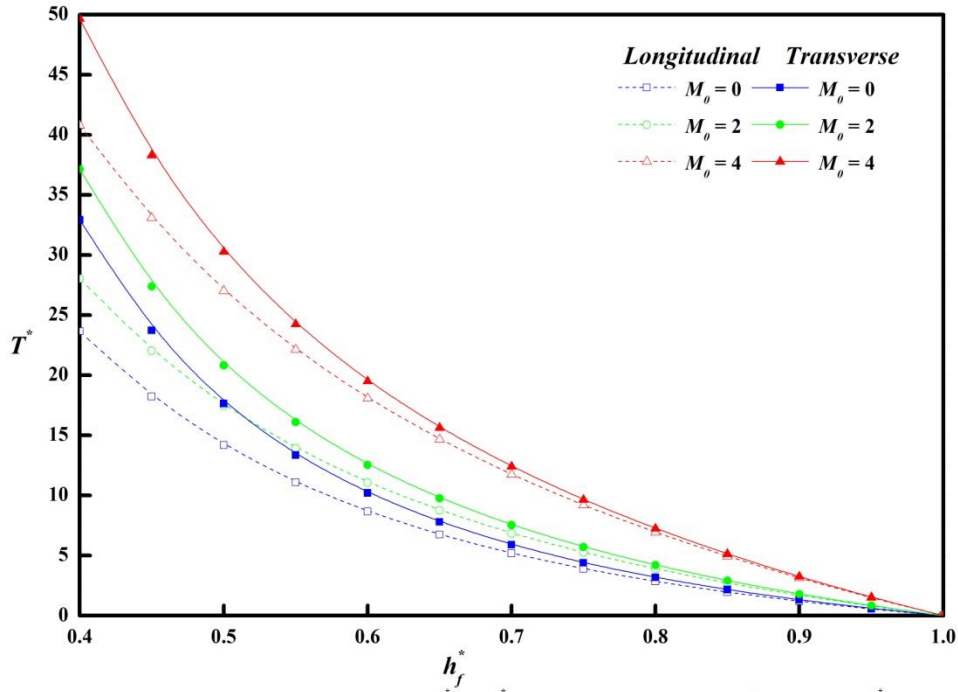

Figure 9 Variation of non-dimensional squeeze film time T^* with h_f^* for different values of M_0 with $C = 0.3, K = 0.7, h_3^* = 0.15$

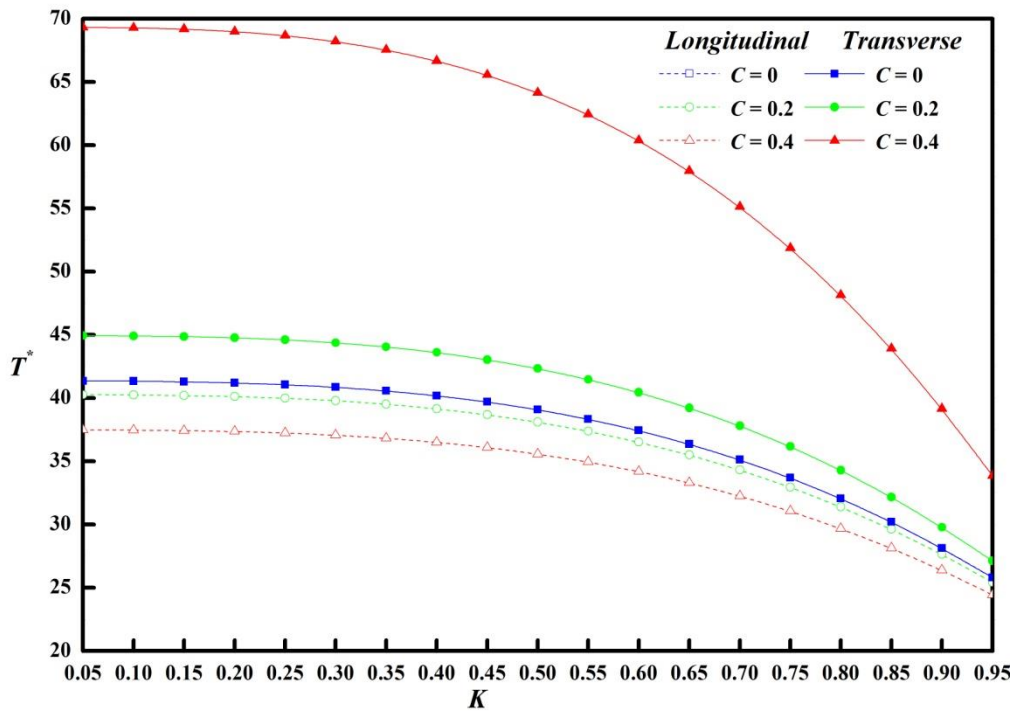

Figure 10 Variation of non-dimensional squeeze film time T^* with K for different values of C with $M_0 = 3, h_f^* = 0.4, h_3^* = 0.15$

Nomenclature

b	breadth of the bearing
B_0	applied magnetic field
h	film thickness
h_0	initial film thickness
h_1	maximum film thickness
h_2	minimum film thickness
h_s^*	step height ratio (h_s / h_2)
K	location parameter
KL	position of the step ($0 < KL < 1$)
L	Length of the bearing plate.
h^*	non-dimensional film thickness $\left(= \frac{h}{h_2} \right)$
h_1^*	non-dimensional maximum film thickness $\left(= \frac{h_1}{h_0} \right)$
p	pressure in the film region in N / m^2 units
P	non-dimensional pressure $\left(= - \frac{ph_0^3}{\mu(dh/dt)A^2} \right)$
Q	Volume flow rate
T	non-dimensional time of approach $\left(= \int_1^{t_1^*} \frac{h_0^2 W dt}{\mu A^2} \right)$
u, v	velocity components in x, y directions
W^*	dimensionless load carrying capacity $\left(= - \frac{Wh_0^3}{\mu(dh/dt)A^2} \right)$
μ	dynamic viscosity of the fluid
σ	conductivity of fluid
W^*	dimensionless load carrying capacity $\left(= - \frac{Wh_0^3}{\mu(dh/dt)A^2} \right)$
μ	dynamic viscosity of the fluid
σ	conductivity of fluid

REFERENCES

1. Dodge FT, Osterle JF, Rouleau WT., *Magneto-hydrodynamic squeeze-film bearings. Journal of Basic Engineering Transactions of the ASME*, 1965, Vol. 87d(3): 805–9.
2. Maki ER, Kuzama DC, *Magneto-hydrodynamic lubrication flow between parallel plates, Journal of Fluid Mechanics*, 1966, Vol. 26, pages 534-43
3. Lin JR, *Magneto-hydrodynamic squeeze film characteristics for finite rectangular plates, Industrial lubrication and Technology*, 2003, Vol. 55(2), 84-89.
4. Snyder, WT, “The magneto-hydrodynamic slider bearing,” *Journal of Basic Engineering*, 1962, Vol. 84, 197-204.
5. Huges WF, *The magneto-hydrodynamic finite step slider bearing, Journal of basic Engineering*, 1963, Vol.85, 129-36.
6. Lin JR, “Magneto-hydrodynamic lubrication of finite slider bearings , *International journal of applied Mechanics and Engineering*, 2002, Vol.7, 1229-46.
7. Anwarr MI, Rodkiewich CM, *Non uniform electrical field effects in MHD slider bearing”, ASME Journal of Lubrication and Technology*, 1973, Vol.95,543-5.
8. Dudzinsky SJ, Young FJ and Huges WF, *On the load capacity of the MHD journal bearing, Journal of lubrication Technology*, 1968, Vol.90(1),139-144.
9. Kamiyama S, *Magneto-hydrodynamic Journal bearing (Report I), ASME journal of Lubrication Technology* 1969, Vol.91, 380-6.
10. Malik M and Singh DV, *Analysis of finite magneto-hydrodynamic journal bearings, Wear*, 1980, Vol.64,273-80.
11. Christensen H, *Stochastic models for hydrodynamic lubrication of rough surfaces. Proceedings of the Institution of Mechanical Engineers Part I*, 1969– 70, 184(55): 1013-1026.
12. Christensen H and Tonder K, *The hydrodynamic lubrication of rough journal bearings’, J Lubr Tech*, 1971, Vol. 95, 162-172.
13. Gupta JL and Deheri GM, *Effect of roughness on the behaviour of squeeze film in a spherical bearing. TribolTrans*, 1996, Vol. 39, 99–102.
14. Turaga.R, Sekhar AS and Majumdar BC, *The effect of roughness parameter of hydrodynamic journal bearing with rough surfaces, Tribol Intl*, 1999, Vol. 32, 231-236.
15. Andharia PI, Gupta JL, Deheri GM., *Effect of surface roughness on hydrodynamic lubrication of slider bearings. Tribol Trans*. 2001, Vol.,44(2), 291–297.
16. Lin JR, Hsu CH, Lai C, *Surface roughness effects on the oscillating squeeze-film behaviour of long partial journal bearings, Comp. and Stru.*, 2002, 80, 297-303.
17. Naduvinamani NB and Gurubasavaraj G, *Surface Roughness Effects on Squeeze films in Curved Circular Plates, Indl. Lubr.Trib.*,2004., Vol.56(6), 346-352.
18. Bujurke NM, Naduvinamani NB and Basti DP, *Effect of surface roughness on the squeeze film lubrication between curved annular plates, Indl. Lubr. Trib.*, 2007, Vol. 59(4), 178-185.